

Narada[®]

VALVE REGULATED TUBULAR GEL BATTERY

Ares(OPzV)
series

OPERATION MANAUL

Version 3.0

NARADA POWER SOURCE CO., LTD

Content**Chapter One Introduction to the Product**

1. Product Characters
2. Types and Indication
3. Dimensions
4. Construction
5. Working Principal

Chapter Two Technical Characteristics

1. Discharge Curve and Discharge Data
2. Charge Curve
3. Internal Resistance and Short Circuit Current

Chapter Three Operation and Maintenance

1. Setting Up The Parameters
2. Capacity and Influence Factors
3. Temperature For Battery Operation
4. Battery Selection
5. Requirement for Charge
6. Storage
7. Maintenance





Chapter Four After Sales Service

Annex 1











Safety and Warning

Please read this manual! It provides very important direction for fix and operation, which can make best capability for the equipment, and elongate the using life.

- For your safety, please do not try to dismantle or open the equipment. The equipment does not contain any spare parts for you. The maintain work can only be done by specially trained service persons.
- As a result of the batteries' latent endanger to health and environment, they should be only changed in our authorization service center. If you need to change the battery or maintain the equipment, please call the nearest service center.
- Batteries can be reclaimed, if it could not be carefully handled, it will do great harms to environment and heath. Please check local laws and regulations to get the validity handle ways or send the equipment to authorized service center.
- The replacement of battery can only be done by persons who know well about the danger and the prevention. When changing the battery, please use the same model and type of sealed lead acid battery.

-  Warning—do not smoke or use fire near batteries
-  Warning—do not use organic solvent to wash batteries
-  Warning—dot not put batteries into the fire, or it may bombed
-  Warning—do not open batteries, it contains electrolyte, which can hurt the skin and eyes.
-  Warning—There may happen shock or short circuit when replacing the batteries. Please operate with tools with insulated handles.

Please take care of the following marks in using

					
Warning	Electricity danger	Protecting your eye	Watch Short-circuits	With adults custody	Do not put batteries into dustbin
					
Read the manual	Fire forbidden	Circle used	The product has past the UL authentication	The product has past the CE authentication	

Chapter One Product Introduction

Product feature:

- 1.1 Design life is above 18 years in float application and cycle life is above 1200 times in 80% DOD (Depth of Discharge) term

Grid alloy with special patented formula
Special negative paste formula
Tubular positive grids to avoid active material from shedding.
Special GEL electrolyte
- 1.2 Reliable seal performance, no acid spillage, and recombination efficiency reach up to 95% after several cycles.
Patented post sealing structure
Delicate security valve with steady open and close pressure
High precise ABS sealing technology or spillage proof & leakage proof glue seal technology
New porous PVC—SiO₂ separator with low-internal resistance
- 1.3 Initial capacity is above 95%, the remaining capacity is above 90% when storage for 3 months (25°C)
- 1.4 Remarkable high rate discharge performance
Gel electrolyte with high conductance rate
Patented grid design
Large section copper structure
- 1.5 Unique flexible connectors made of rubber wrapped with copper wires with
Patented silver-coated ends
Assure the good connections of post and connectors and low connection resistance
Combination of suppleness and rigidity for more flexible connections
Monitor hole designed
- 1.6 Flexible and convenient installation, slinky outside looking
Shockproof blocking assembling
Satisfy customer's individual requirements and provide up to 8-class shockproof
Imported case and lid comply to DIN 40742 standard.
- 1.7 Optional ABS container material criterion of UL94-HB or UL94-V0.

2. Types and Dimensions

Table 1-1

Cell Type (Ares series)	Rated Voltage (V)	Rated Capacity (Ah)				Dimensions (mm)			Weight (kg)
		C ₁₀	C ₃	C ₁	Length	Width	Height	Overall Height	
4OPzV 200	2	200	150	100	103	206	356	389	20
6OPzV 300	2	300	225	150	145	206	356	389	28
6OPzV 400	2	400	300	200	145	206	473	505	35
7OPzV 500	2	500	375	250	166	206	473	505	41
6OPzV 600	2	600	450	300	145	206	646	678	49
8OPzV 800	2	800	600	400	191	210	646	678	65
10OPzV 1000	2	1000	750	500	233	210	646	678	80
12OPzV1200	2	1200	900	600	275	210	646	678	93
12OPzV 1500	2	1500	1125	750	275	210	795	827	117
16OPzV 2000	2	2000	1500	1000	399	212	770	802	155
20OPzV2500	2	2500	1875	1250	487	212	770	802	192
24OPzV3000	2	3000	2250	1500	576	212	770	802	228

Dimension drawing (mm)

Ares(OPzV) series: 200Ah~600Ah

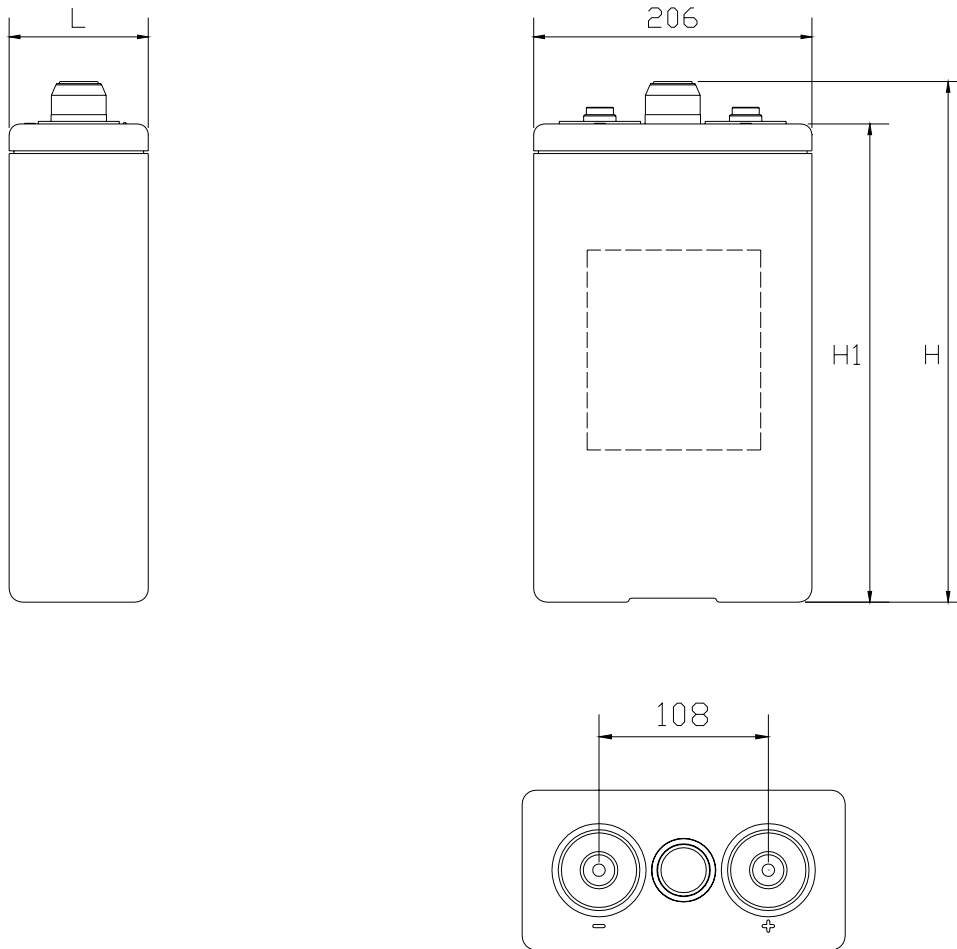

Type	4OPzV200	6OPzV300	6OPzV400	7OPzV500	6OPzV-600
L	102	145	145	166	145
H1	356	356	473	473	646
H	389	389	505	505	678

Dimension drawing (mm)

Ares(OPzV) series: 800Ah~1500Ah

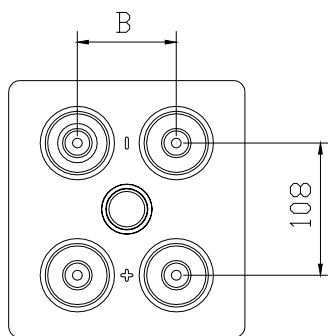
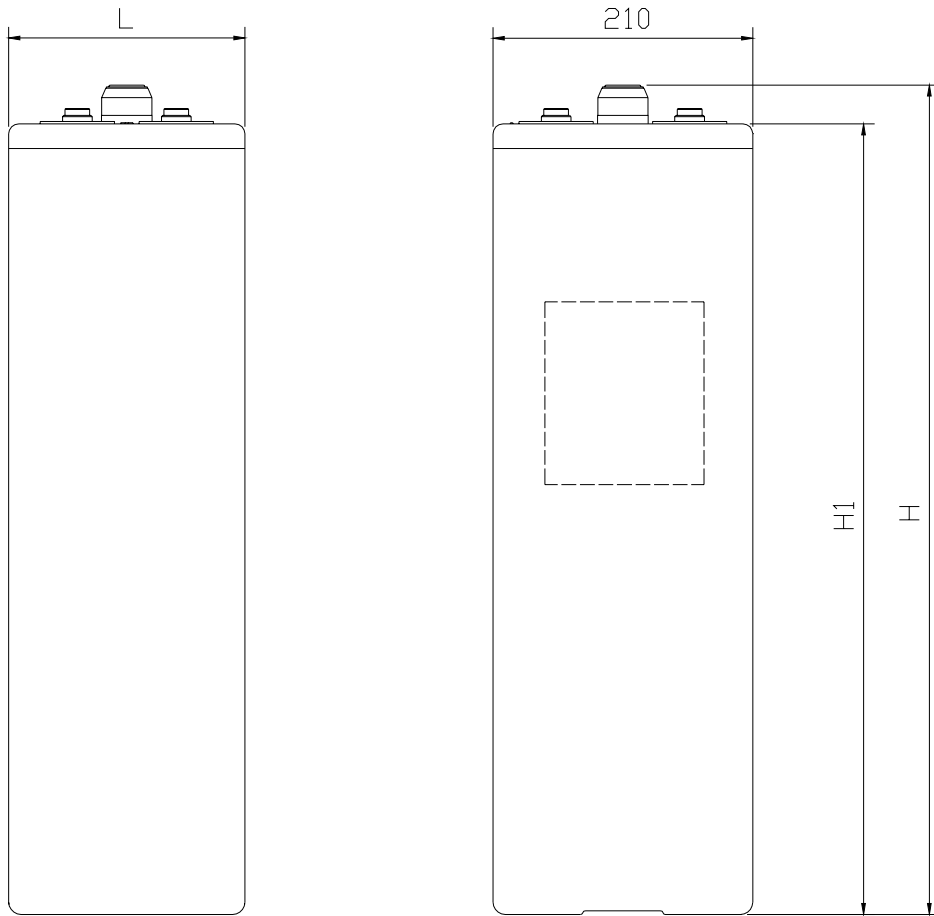

Type	80PzV800	100PzV1000	120PzV1200	120PzV1500
L	191	233	275	275
B	80	110	140	140
H1	646	646	646	795
H	678	678	678	827

Dimension drawing (mm)

160PzV 2000

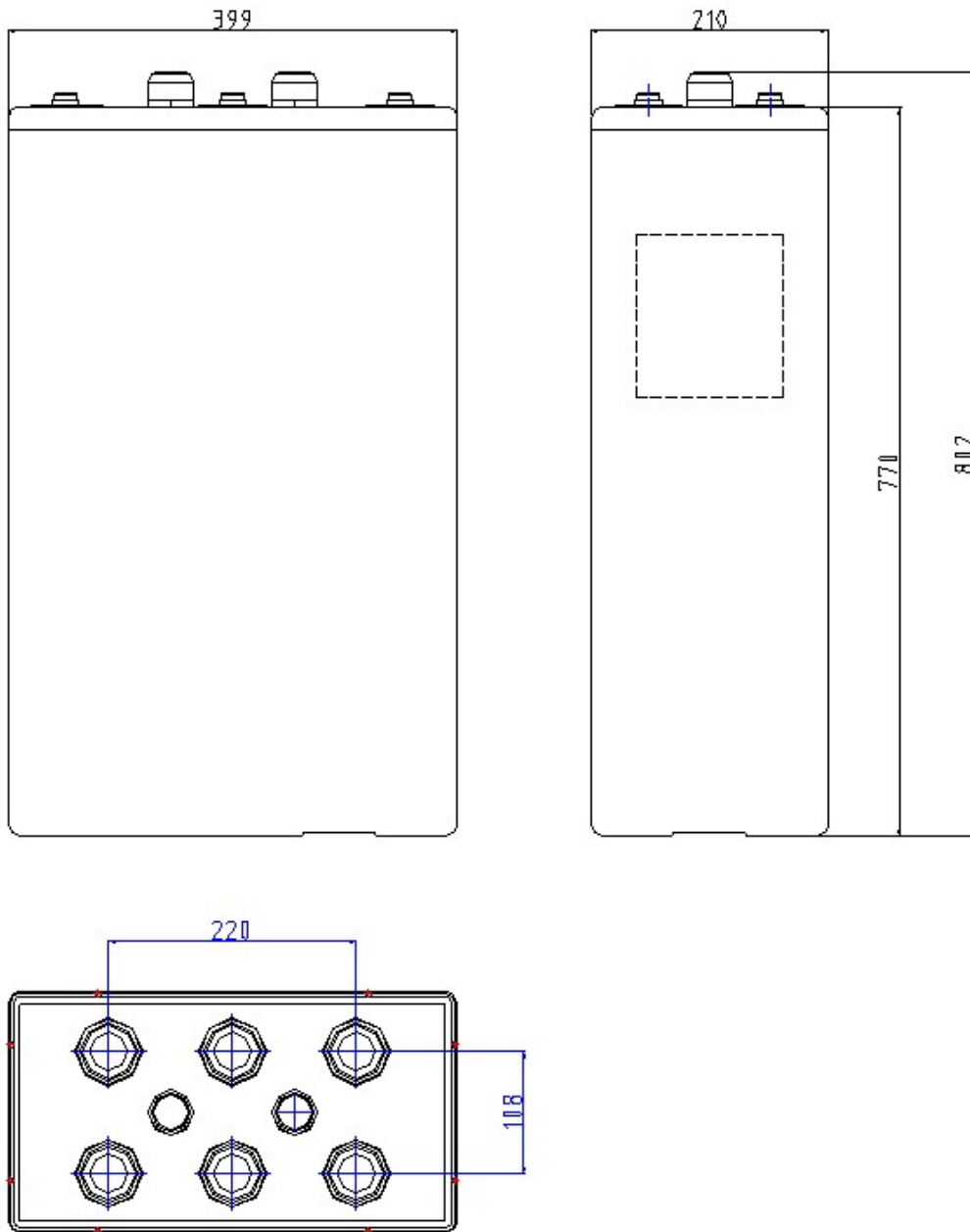

Dimension drawing (mm)
200PzV2500 and 240PzV3000:

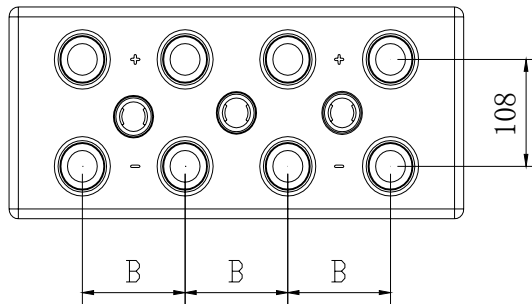
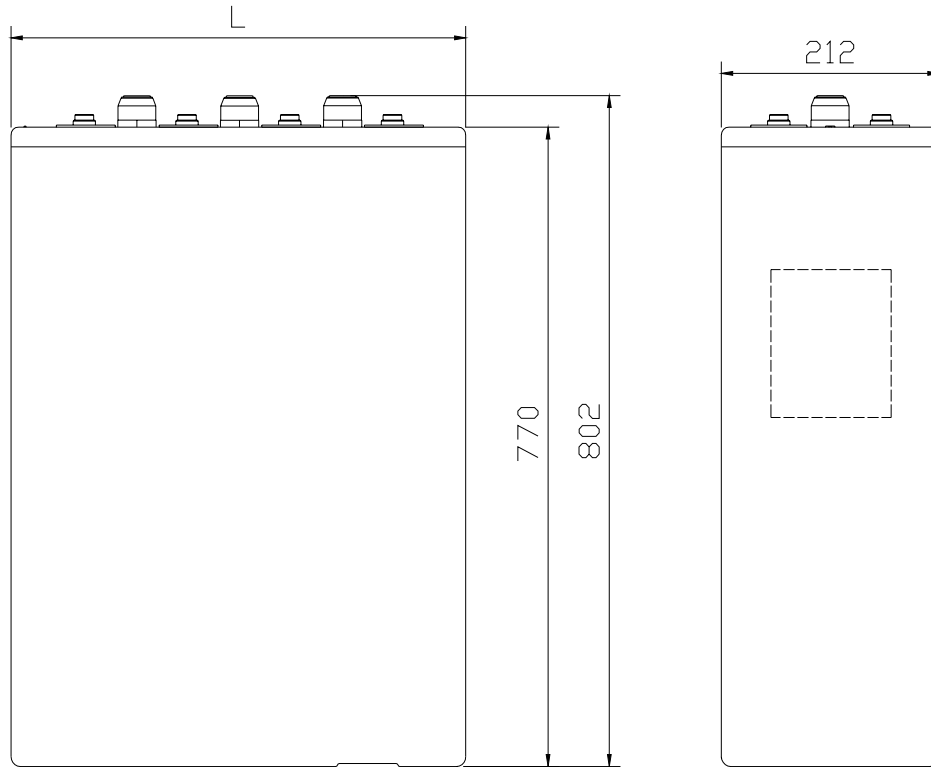

Type	200PzV2500	240PzV3000
L	478	576
B	110	140

3. Construction

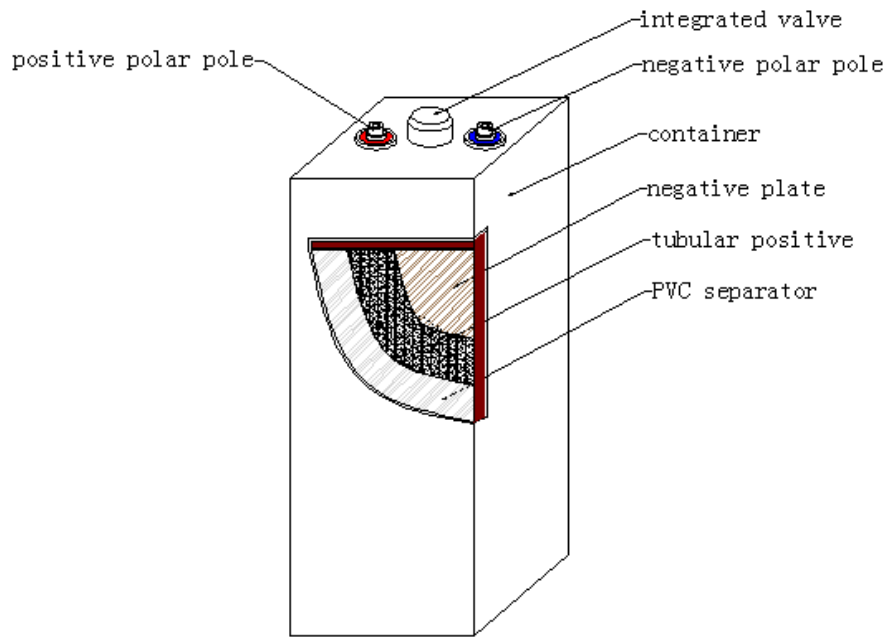
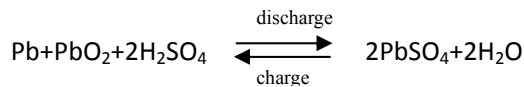

Fig. 1-1 construction

Fig.1-1 Construction

4. Working Principle

The chemical reactions take place in lead acid battery is as follows:



Following by-reaction ① takes place in ordinary lead acid battery:

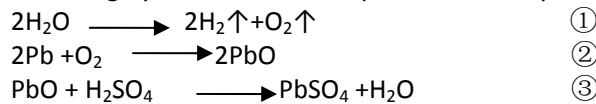

For normal AGM battery, there is certain porous ratio inside AGM (micro porous adsorptive glass mad) separator. Thus there is a path existing between the positive and the negative. Also special alloy grid is chosen to increase vent hydrogen over-potential gassing on the negative plates, which prevent generation of Hydrogen. Otherwise, the oxygen generated from positive diffuses through separator to the negative and the oxygen gas reacts quickly and is recombined into water. For Gel battery, we adopt gel electrolyte and PVC-SiO₂ Separator to set up oxygen cycle principle: Battery is full of gel electrolyte inside, and A 3-D porous network is formed with framework of SiO₂. The net contains electrolyte necessary for battery. At initial stage, the construction is not steady. As time goes on, the framework is shrink and some cracks appeared in the gel. The cracks exist between pos.& neg. plates and separator and become a path between the positive and the negative. Thus it is possible to build GEL battery in sealed structure.

Chapter Two Technical Characteristics

1. Discharge Curve and Discharge Data

Fig. 2-1 Discharge Performance Curves at Different Discharge Rates (25°C)

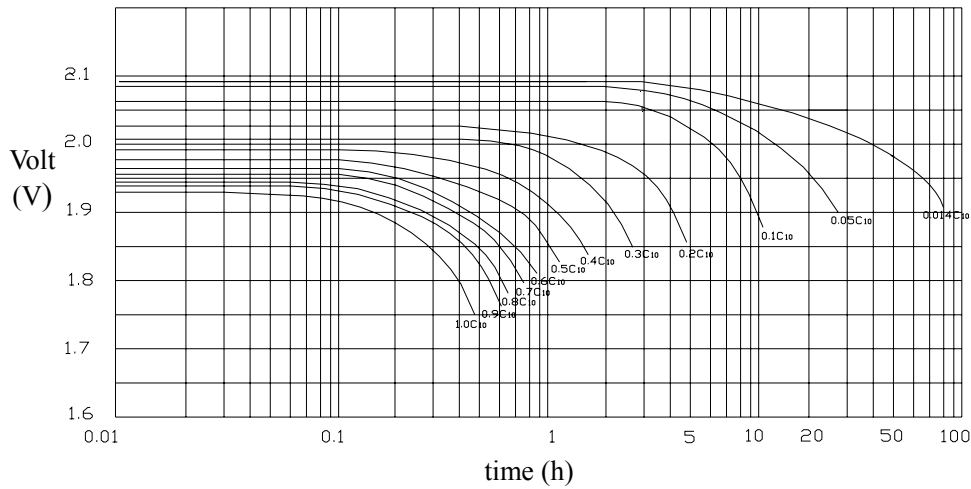

2. Charge Performance

Fig. 2-2 shows recharge characteristics of 100% DOD battery with current of 0.1C_{10A} and limit voltage of 2.35V/Cell (25°C). It can be found that the fully discharged battery is 105% recharged in 24 hours. Broken line is for charge performance of 50% DOD battery

Fig.2-2 Recharge characteristics

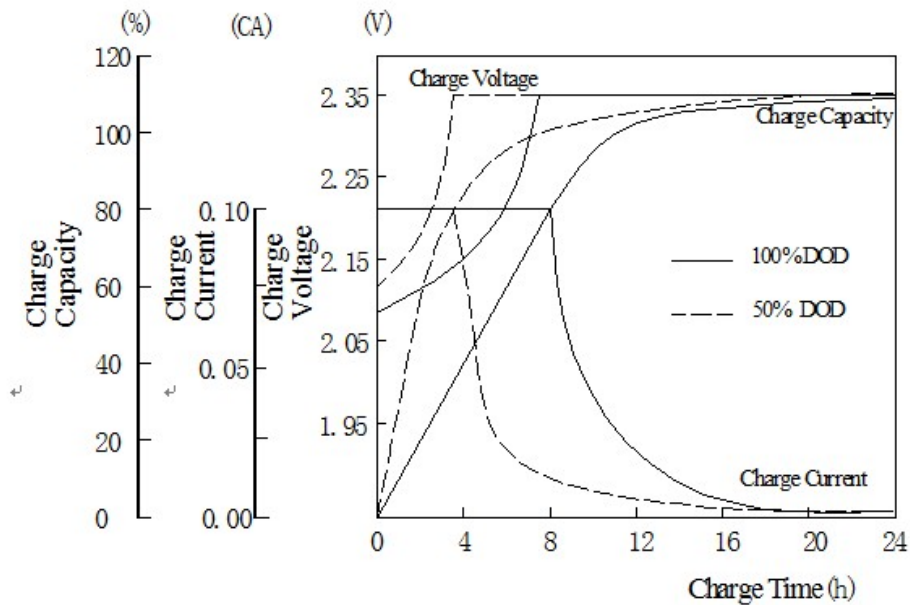

Table 2 - 1 Constant Current Discharge Data Unit: A (25°C)

40PzV200													
End voltage	15min	30min	1h	2h	3h	4h	5h	6h	8h	10h	24h	48h	100h
1.60V	219	175	120	74	54	43	36.5	32.1	25.9	21.2	9.5	5.2	2.9
1.65V	212	169	117	73	53	42	36.1	31.7	25.7	21.1	9.5	5.2	2.9
1.70V	199	162	114	71	52	42	35.6	31.2	25.4	21.0	9.4	5.1	2.8
1.75V	189	156	110	69	51	41	35.0	30.6	24.9	20.7	9.2	5.1	2.8
1.80V	167	143	105	67	50	40	34.2	29.8	24.3	20.1	9.0	5.0	2.7
1.85V	140	120	98	63	48	39	33.1	28.8	23.6	19.8	8.7	4.7	2.6
1.90V	106	103	78	55	43	36	30.8	26.6	21.4	17.8	8.0	4.4	2.4
60PzV300													
End voltage	15min	30min	1h	2h	3h	4h	5h	6h	8h	10h	24h	48h	100h
1.60V	329	263	180	112	81	64	54.8	48.2	38.8	31.8	14.3	7.8	4.4
1.65V	318	254	176	109	79	63	54.2	47.6	38.5	31.7	14.3	7.8	4.3
1.70V	299	244	170	107	78	62	53.4	46.8	38.1	31.5	14.1	7.7	4.3
1.75V	284	235	166	104	76	61	52.5	45.9	37.3	31.1	13.8	7.6	4.1
1.80V	250	215	158	100	75	60	51.3	44.7	36.5	30.1	13.5	7.5	4.0
1.85V	211	181	146	95	72	58	49.7	43.2	35.4	29.7	13.1	7.1	3.9
1.90V	159	154	117	83	65	54	46.2	39.9	32.1	26.7	12.0	6.7	3.6
60PzV400													
End voltage	15min	30min	1h	2h	3h	4h	5h	6h	8h	10h	24h	48h	100h
1.60V	450	359	246	153	110	87	74.8	65.8	53.0	43.5	19.5	10.7	6.0
1.65V	434	347	240	149	108	86	74.0	65.0	52.6	43.3	19.5	10.6	5.9
1.70V	409	333	233	146	107	85	73.0	64.0	52.0	43.1	19.3	10.5	5.8
1.75V	387	320	226	142	104	84	71.8	62.7	51.0	42.4	18.9	10.4	5.7
1.80V	342	293	215	137	102	82	70.1	61.1	49.8	41.1	18.5	10.2	5.5
1.85V	288	247	200	130	99	79	67.9	59.0	48.4	40.6	17.9	9.7	5.3
1.90V	217	210	160	113	88	74	63.1	54.5	43.9	36.5	16.4	9.1	4.9
70PzV500													
End voltage	15min	30min	1h	2h	3h	4h	5h	6h	8h	10h	24h	48h	100h
1.60V	543	433	297	184	133	105	90.3	79.4	64.0	52.5	23.5	12.9	7.2
1.65V	524	419	290	180	131	104	89.3	78.5	63.5	52.2	23.5	12.8	7.1
1.70V	493	402	281	176	129	103	88.1	77.2	62.8	52.0	23.3	12.7	7.0
1.75V	468	387	273	172	126	101	86.6	75.7	61.6	51.2	22.8	12.6	6.8
1.80V	413	354	260	165	123	99	84.6	73.8	60.2	49.7	22.3	12.3	6.6
1.85V	347	298	242	156	119	96	81.9	71.3	58.5	49.0	21.6	11.7	6.4
1.90V	262	254	193	136	106	89	76.2	65.8	53.0	44.1	19.8	11.0	5.9
60PzV600													
End voltage	15min	30min	1h	2h	3h	4h	5h	6h	8h	10h	24h	48h	100h
1.60V	658	525	360	223	161	128	110	96	77.6	63.6	28.5	15.66	8.78
1.65V	635	508	351	219	159	126	108	95	77.0	63.3	28.5	15.53	8.65
1.70V	598	487	341	214	156	125	107	94	76.1	63.0	28.2	15.40	8.51
1.75V	567	469	331	208	153	122	105	92	74.7	62.1	27.6	15.21	8.28
1.80V	500	429	315	200	149	120	103	89	72.9	60.2	27.0	14.96	8.02
1.85V	421	361	293	190	144	116	99.3	86.4	70.9	59.4	26.1	14.24	7.76
1.90V	318	308	234	165	129	108	92.4	79.8	64.2	53.4	24	13.3	7.15
80PzV800													
End voltage	15min	30min	1h	2h	3h	4h	5h	6h	8h	10h	24h	48h	100h
1.60V	874	698	478	296	214	170	145.4	127.9	103.1	84.5	37.9	20.8	11.7
1.65V	843	675	467	290	211	168	143.8	126.3	102.3	84.1	37.9	20.6	11.5

1.70V	794	647	453	284	207	165	141.8	124.3	101.1	83.7	37.5	20.5	11.3
1.75V	753	623	440	276	203	163	139.4	121.9	99.2	82.5	36.7	20.2	11.0
1.80V	664	570	418	266	198	159	136.3	118.7	96.8	79.9	35.9	19.9	10.6
1.85V	559	479	389	252	192	154	131.9	114.7	94.1	78.9	34.7	18.9	10.3
1.90V	422	409	311	219	171	143	122.7	106.0	85.3	70.9	31.9	17.7	9.5
100PzV1000													
End voltage	15min	30min	1h	2h	3h	4h	5h	6h	8h	10h	24h	48h	100h
1.60V	1088	869	595	369	266	211	181.0	159.2	128.3	105.2	47.1	25.9	14.5
1.65V	1050	840	581	362	262	209	179.1	157.2	127.4	104.7	47.1	25.7	14.3
1.70V	989	805	564	353	258	206	176.6	154.8	125.9	104.2	46.6	25.5	14.1
1.75V	937	775	547	344	252	202	173.6	151.8	123.5	102.7	45.7	25.2	13.7
1.80V	827	709	521	331	247	198	169.6	147.8	120.5	99.5	44.7	24.7	13.3
1.85V	696	597	484	313	239	192	164.2	142.8	117.1	98.2	43.2	23.5	12.8
1.90V	526	509	387	273	213	179	152.8	131.9	106.1	88.3	39.7	22.0	11.8
120PzV1500													
End voltage	15min	30min	1h	2h	3h	4h	5h	6h	8h	10h	24h	48h	100h
1.60V	1630	1302	892	553	399	317	271	239	192	158	70.6	38.8	21.7
1.65V	1573	1259	870	542	393	313	268	236	191	157	70.6	38.5	21.4
1.70V	1482	1207	844	529	386	308	265	232	189	156	69.9	38.2	21.1
1.75V	1405	1162	820	515	378	303	260	227	185	154	68.4	37.7	20.5
1.80V	1239	1063	780	496	369	297	254	221	181	149	67.0	37.1	19.9
1.85V	1043	894	726	470	358	288	246	214	176	147	64.8	35.3	19.2
1.90V	788	763	580	409	320	268	229	198	159	132	59.5	33.0	17.7
160PzV2000													
End voltage	15min	30min	1h	2h	3h	4h	5h	6h	8h	10h	24h	48h	100h
1.60V	2171	1734	1188	737	532	422	361	318	256	210	94.1	51.7	29.0
1.65V	2096	1677	1159	722	524	417	357	314	254	209	94.1	51.2	28.5
1.70V	1973	1608	1125	705	515	411	352	309	251	208	93.1	50.8	28.1
1.75V	1871	1548	1092	686	504	404	347	303	246	205	91.1	50.2	27.3
1.80V	1650	1416	1040	660	492	395	339	295	241	200	89.2	49.4	26.5
1.85V	1389	1191	967	626	476	383	328	285	234	196	86.2	47.0	25.6
1.90V	1049	1016	772	545	426	356	305	263	212	176	79.2	43.9	23.6
160PzV2500													
End voltage	15min	30min	1h	2h	3h	4h	5h	6h	8h	10h	24h	48h	100h
1.60V	2714	2167	1485	921	665	527	452	397	320	262	118	65	36
1.65V	2619	2096	1449	902	655	521	447	392	318	261	118	64	36
1.70V	2467	2009	1406	881	644	514	441	386	314	260	116	64	35
1.75V	2339	1935	1365	858	630	505	433	379	308	256	114	63	34
1.80V	2063	1770	1299	825	615	494	423	369	301	250	111	62	33
1.85V	1737	1489	1208	782	595	479	410	356	292	245	108	59	32
1.90V	1312	1271	965	681	532	446	381	329	265	220	99	55	29
240PzV3000													
End voltage	15min	30min	1h	2h	3h	4h	5h	6h	8h	10h	24h	48h	100h
1.60V	3257	2601	1782	1105	797	633	542	477	384	315	141	77.5	43.5
1.65V	3143	2515	1739	1083	786	625	536	471	381	313	141	76.9	42.8
1.70V	2960	2411	1687	1057	772	616	529	463	377	312	140	76.2	42.1
1.75V	2807	2322	1638	1029	756	606	520	454	370	307	137	75.3	41.0
1.80V	2475	2124	1559	990	738	593	508	443	361	300	134	74.1	39.7
1.85V	2084	1787	1450	939	714	575	492	428	351	294	129	70.5	38.4
1.90V	1574	1525	1158	817	639	535	457	395	318	264	119	65.8	35.4

Table 2—2 Constant Power Discharge Data Unit: W (25℃)

4OPzV200												
End voltage	15min	30min	1h	2h	3h	4h	5h	6h	8h	10h	16h	24h
1.60V	439	347	266	146	111	88	74.1	64.8	53.2	44.7	28.8	19.6
1.65V	418	329	247	145	110	88	73.6	63.4	52.9	44.4	28.6	19.4
1.70V	399	314	232	143	109	86	72.6	62.5	52.2	43.8	28.3	19.2
1.75V	377	301	218	139	106	83	70	61.6	51.3	43	27.7	18.9
1.80V	353	289	206	134	103	81	66.8	58.5	48.9	40.8	26.3	17.9
1.85V	330	278	191	129	98	77	65	56	46.4	39.1	25.2	17.2
1.90V	309	254	170	117	95	74	63.3	51	42.2	35.5	22.9	15.6
60PzV300												
End voltage	15min	30min	1h	2h	3h	4h	5h	6h	8h	10h	16h	24h
1.60V	658	521	399	219	166	132	111.1	97.3	79.9	67.1	43.3	29.4
1.65V	627	494	371	218	165	131	110.4	96.6	79.3	66.6	42.9	29.2
1.70V	598	471	348	215	163	130	108.9	95.3	78.2	65.7	42.4	28.8
1.75V	566	452	327	209	159	125	105	93.2	77	64.5	41.6	28.4
1.80V	530	434	309	201	155	122	100.2	87.7	73.4	61.2	39.5	26.9
1.85V	496	417	287	194	147	116	97.5	84.1	69.7	58.7	37.9	25.8
1.90V	463	381	256	176	142	111	94.6	76.3	63.2	53.2	34.3	23.3
60PzV400												
End voltage	15min	30min	1h	2h	3h	4h	5h	6h	8h	10h	16h	24h
1.60V	899	712	545	299	227	181	151.9	131.9	109.2	91.7	59.2	40.1
1.65V	856	674	507	297	226	180	150.9	130.6	108.4	91.1	58.8	39.9
1.70V	817	644	475	293	223	177	148.8	128.7	106.9	89.8	57.9	39.3
1.75V	774	618	447	285	217	170	143.5	126.4	105.2	88.2	56.9	38.7
1.80V	724	593	422	275	211	166	136.9	120	100.2	83.6	54	36.7
1.85V	677	570	392	264	201	158	133.3	115	95.2	80.2	51.8	35.2
1.90V	633	520	349	240	194	151	130	104.3	86.3	72.7	46.9	31.9
70PzV500												
End voltage	15min	30min	1h	2h	3h	4h	5h	6h	8h	10h	16h	24h
1.60V	1086	860	658	361	275	218	183.4	159	131.8	110.7	71.5	48.5
1.65V	1034	814	612	359	273	217	182.1	157.5	130.9	109.9	70.9	48.1
1.70V	987	777	573	354	269	214	179.6	155.4	129.1	108.4	70	47.5
1.75V	934	746	540	344	262	205	173.3	152.5	127	106.4	68.7	46.8
1.80V	874	716	509	332	255	200	165.3	144.8	121	101	65.2	44.3
1.85V	818	688	474	319	243	191	160.9	138.7	115	96.8	62.5	42.5
1.90V	764	628	422	290	234	182	156.1	125.8	104.3	87.8	56.7	38.5
60PzV600												

End voltage	15min	30min	1h	2h	3h	4h	5h	6h	8h	10h	16h	24h
1.60V	1316	1042	798	438	333	265	222	193	159.7	134.2	86.6	58.7
1.65V	1253	987	742	435	331	263	221	191	158.6	133.3	86.1	58.3
1.70V	1196	942	695	429	326	259	218	188.5	156.5	131.4	84.8	57.5
1.75V	1132	904	654	417	318	249	210	185	153.9	129	83.3	56.7
1.80V	1059	868	617	402	309	243	200	175.5	146.7	122.4	79	53.7
1.85V	991	834	574	387	294	231	195	168.1	140	117.3	75.7	51.5
1.90V	926	761	511	351	284	220	190	152.6	126.4	106.4	68.7	46.7

80PzV800

End voltage	15min	30min	1h	2h	3h	4h	5h	6h	8h	10h	16h	24h
1.60V	1748	1384	1060	582	442	351	295.2	256	212.1	178.2	115	78
1.65V	1664	1311	985	578	439	349	293.2	254	210.7	177	114.3	77.5
1.70V	1588	1251	923	570	433	344	289.1	250	207.8	174.5	112.7	76.4
1.75V	1503	1201	869	554	422	331	278.9	245.5	204.4	171.3	110.6	75.3
1.80V	1406	1153	819	534	410	323	266.1	233	194	162.5	105	71.3
1.85V	1316	1108	762	514	390	307	259	223	185	155.8	100.6	68.4
1.90V	1230	1011	679	466	377	290	252	202.5	168	141.3	91.2	62

100PzV1000

End voltage	15min	30min	1h	2h	3h	4h	5h	6h	8h	10h	16h	24h
1.60V	2176	1723	1319	724	550	438	367.5	318	264.1	221.8	143.2	97.1
1.65V	2072	1632	1227	719	547	435	365	316	262.3	220.3	142.2	96.4
1.70V	1977	1557	1149	709	539	429	360	311.5	258.7	217.3	140.3	95.1
1.75V	1872	1495	1081	689	526	412	347.2	306	254.4	213.3	137.7	93.7
1.80V	1751	1435	1020	665	511	402	331.3	290	242.5	202.4	130.7	88.8
1.85V	1638	1379	949	640	486	382	322.4	278	230.3	193.9	125.2	85.1
1.90V	1531	1258	845	580	470	363	311	252	209	175.9	113.5	77.2

120PzV1200

End voltage	15min	30min	1h	2h	3h	4h	5h	6h	8h	10h	16h	24h
1.60V	2250	1877	1343	862	659	525	431	381	317	266	171	117
1.65V	2233	1861	1333	858	651	521	428	378	315	264	170	116
1.70V	2210	1842	1317	848	642	515	423	374	310	261	168	114
1.75V	2167	1807	1293	827	635	505	415	367	305	256	165	112
1.80V	2060	1715	1224	789	626	480	394	348	291	243	156	106
1.85V	1967	1638	1170	754	583	458	376	332	277	232	150	102
1.90V	1865	1553	1111	715	553	434	356	315	263	220	141	97

120PzV1500

End voltage	15min	30min	1h	2h	3h	4h	5h	6h	8h	10h	16h	24h
1.60V	3260	2582	1977	1085	825	656	550.7	476.6	395.8	332.4	214.6	145.5
1.65V	3104	2445	1838	1078	819	651	547	474	393	330.2	213.2	144.5

1.70V	2963	2334	1722	1063	808	642	539.4	467	387.6	325.6	210.2	142.5
1.75V	2805	2240	1620	1033	788	617	520.3	458	381.3	319.6	206.3	140.5
1.80V	2624	2150	1529	996	766	602	496.5	435	360	303.2	195.7	133
1.85V	2455	2066	1422	959	728	572	483.1	416.6	345.2	290.6	187.6	127.5
1.90V	2294	1885	1266	870	704	550	470.5	378	313	263.6	170.2	115.7
16OPzV2000												
End voltage	15min	30min	1h	2h	3h	4h	5h	6h	8h	10h	16h	24h
1.60V	4343	3439	2633	1445	1099	873	733.6	635	527.1	442.8	285.9	193.8
1.65V	4135	3257	2449	1436	1091	867	728.6	630.5	523.5	439.8	283.9	192.5
1.70V	3947	3109	2294	1416	1076	855	718.5	622	516.3	433.7	280	189.9
1.75V	3736	2983	2158	1376	1049	822	693	610.2	507.9	425.7	274.8	187.1
1.80V	3495	2864	2036	1327	1020	802	661.3	579	480	403.9	260.7	177.2
1.85V	3270	2752	1894	1277	970	762	643.5	554.9	460	387.1	250	169.8
1.90V	3056	2511	1686	1158	937	742	622.6	503.2	417	351.1	226.7	154
20OPzV2500												
End voltage	15min	30min	1h	2h	3h	4h	5h	6h	8h	10h	16h	24h
1.60V	5429	4299	3291	1806	1374	1091	917	794	659	554	357	242
1.65V	5169	4071	3061	1795	1364	1084	911	788	654	550	355	241
1.70V	4934	3886	2868	1770	1345	1069	898	778	645	542	350	237
1.75V	4670	3729	2698	1720	1311	1028	866	763	635	532	344	234
1.80V	4369	3580	2545	1659	1275	1003	827	724	600	505	326	222
1.85V	4088	3440	2368	1596	1213	953	804	694	575	484	313	212
1.90V	3820	3139	2108	1448	1171	903	783	629	521	439	283	193
24OPzV3000												
End voltage	15min	30min	1h	2h	3h	4h	5h	6h	8h	10h	16h	24h
1.60V	6515	5159	3950	2168	1649	1310	1100	953	791	664	429	291
1.65V	6203	4886	3674	2154	1637	1301	1093	946	785	660	426	289
1.70V	5921	4664	3441	2124	1614	1283	1078	933	774	651	420	285
1.75V	5604	4475	3237	2064	1574	1233	1040	915	762	639	412	281
1.80V	5243	4296	3054	1991	1530	1203	992	869	720	606	391	266
1.85V	4905	4128	2841	1916	1455	1143	965	832	690	581	375	255
1.90V	4584	3767	2529	1737	1406	1083	936	755	626	527	340	231

Note: The above data only represent battery experimental values, not as the battery acceptance and judge standard.

3. Internal resistance and short circuit current

The internal resistance of the battery is a dynamic nonlinear parameter that is continuously changed along with the temperature and discharge state. The internal resistance is the lowest when Ares series battery is fully charged. The table 2-3 shows the internal resistance and short circuit current of Narada battery in fully charged state according to IEC60896. If the voltage decrease 0V due to short circuit that can damage the battery.

Table 2-3 Internal resistance and short circuit current (25°C)

Type	Internal Resistance (mΩ)	Short Circuit Current (A)
4OPzV200	0.939	2221
6OPzV300	0.615	3320
6OPzV400	0.512	4350
7OPzV500	0.495	4890
6OPzV600	0.425	6180
8OPzV800	0.294	7270
10OPzV1000	0.238	8785
12OPzV1200	0.210	9500
12OPzV1500	0.185	10950
16OPzV2000	0.142	14620
20OPzV2500	0.126	17255
24OPzV3000	0.108	20300

Chapter Three Operation and Maintenance

1. Setting Up The Parameters

Below is the table for data set up on Switch power. Discharge times and DOD vary in different circumstance. In some frequent power off places, batteries are discharged a lot without sufficient charge, so we need to raise float voltage and current to make battery full charged in a short time.

Table 3-1 Set up the parameter on Switch Power (48V system)

Parameter	Unit	Normal Place	Frequent Power Off place
Floating Voltage	V	54	54
Equalization Voltage	V	56.4	56.4
Current	A	0.1C ₁₀	0.1C ₁₀
Limited current for charge	A	0.20C ₁₀	0.20C ₁₀
Equalization Charge Cycle	Day	90	30
Equalization Charge Time	h	24	24
Condition to change Float Charge to Equalization Charge	(mA/Ah)	>50	>50
Condition to change Equalization Charge to Float charge	mA/Ah	<5	<5
Voltage under load	V	45.6	45.6
Broke Voltage	V	44	45
Recover Voltage	V	49	50
High Voltage Warning	V	57.6	57.6
Low Voltage Warning	V	46	47
Temperature Compensate Ratio With Floating Voltage	V/°C	-0.072	-0.072
Temperature Compensate Ratio With Equalization Voltage	V/°C	-0.120	-0.120
High Temperature Warning	°C	35	35

- The above data are set at an ambient temperature of 25°C. Please refer to Table 3-2 for data under other temperature.
- Please refer to above data especially for frequent power off place.

2. Capacity Of Battery and factors to affect capacity

The capacity of battery is the capacity that battery can be discharged on the established conditions, expressed as signal C. The usual unit of capacity is ampere hour, shortened as AH. For example, C₁₀ shows the battery capacity for 10-hour rate. C₃ shows the battery capacity for 3-hour rate.

The capacity can be expressed in Rated Capacity or Actual Capacity. Table 1-1 shows the Rated Capacity for Ares range Battery. The Actual Capacity is the product of the discharge current and the discharge time, the unit is AH. The actual capacity is affected by discharge rate, discharge

mode, end voltage and temperature during operation.

3 Operating Temperatures

Ares series battery can be operated between $-40^{\circ}\text{C} \sim +50^{\circ}\text{C}$.The best temperature is $15^{\circ}\text{C} \sim 25^{\circ}\text{C}$.If the operating temperature is too high, it will decrease battery life; if the operating temperature is too low, it will decrease battery capacity. Table 3-2 is working temperature range for battery.

Tab. 3-2 Working temperature range

Working condition	Temperature range	Optimum temperature
Discharge	$-40^{\circ}\text{C} \sim 50^{\circ}\text{C}$	$15^{\circ}\text{C} \sim 25^{\circ}\text{C}$
Charge	$-20^{\circ}\text{C} \sim 50^{\circ}\text{C}$	$15^{\circ}\text{C} \sim 25^{\circ}\text{C}$
Storage	$-20^{\circ}\text{C} \sim 40^{\circ}\text{C}$	$15^{\circ}\text{C} \sim 25^{\circ}\text{C}$

Temperature will affect battery capacity. Fig. 3-1 is capacity(C10, end voltage 1.80V) vs. temperature curve. From Fig. 3-1, if the temperature is too low, the capacity will decrease, for example, the capacity will decrease 15% if temperature fell to 0°C from 25°C ; and too low temperature will cause battery long term insufficient charged, also will cause no discharge and negative plates sulfated.

The capacity will increase when temperature raises. For example the capacity will increase 5% if temperature rises up to 35°C from 25°C . But the capacity increase very slow if temperature goes on increasing.

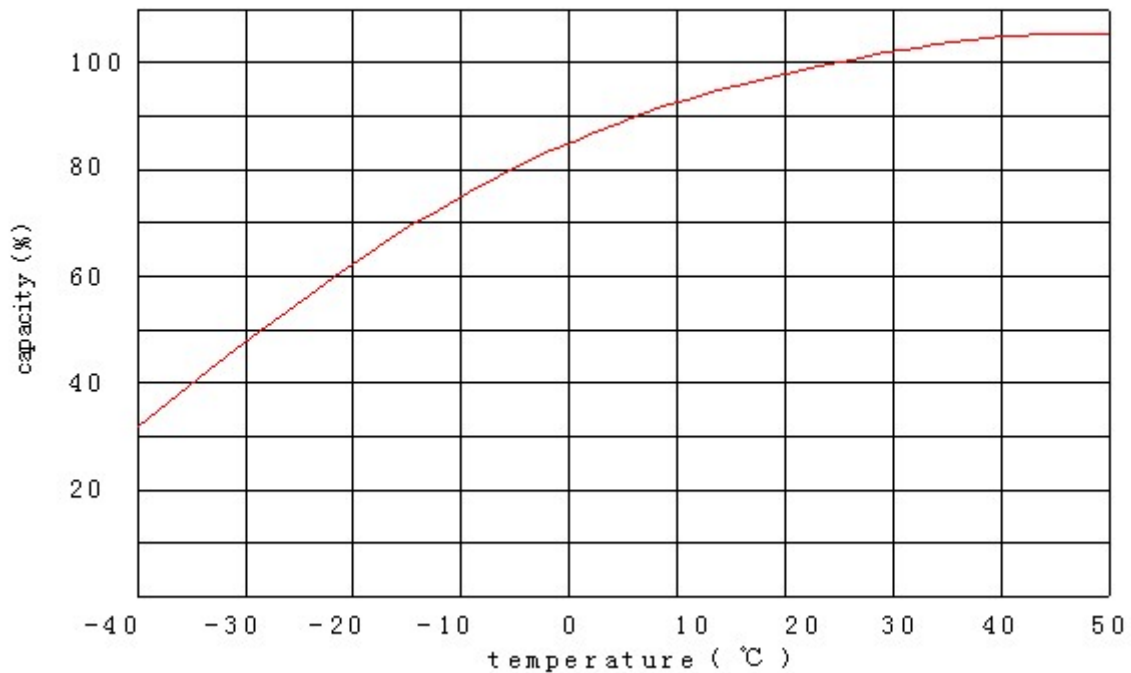

Fig. 3-1 Capacity vs. Temperature

3. 2 Temperature Vs. Charging Voltage

The purpose of choosing certain floating voltage and equalization voltage is to make battery operating under best circumstance. If the floating voltage is higher, then the floating current is also higher, it will accelerate corruption of the grid and shorten life of the battery. If the floating

voltage is lower, the battery can't be kept in fully charged state, this will cause sulfation, decrease the capacity, and also shorten the life of the battery. The float voltage is 2.23V/cell to 2.25V/cell and temperature compensation coefficient is -3mV/°C per cell. The battery need an equalization charge regularly. The equalization voltage is 2.35V at 25°C. Meanwhile, the equalization voltage should adjust with the ambient temperature. The temperature compensation coefficient is -5mV/°C per cell.

Table 3-3 Relationship of ambient temperature and voltage

Ambient Temperature (°C)	Float voltage (V/cell)	Equalization voltage (V/cell)
5	2.29	2.45
10	2.27	2.43
15	2.26	2.40
20	2.24	2.38
25	2.23	2.35
30	2.22	2.33
35	2.20	2.30
40	2.19	2.28

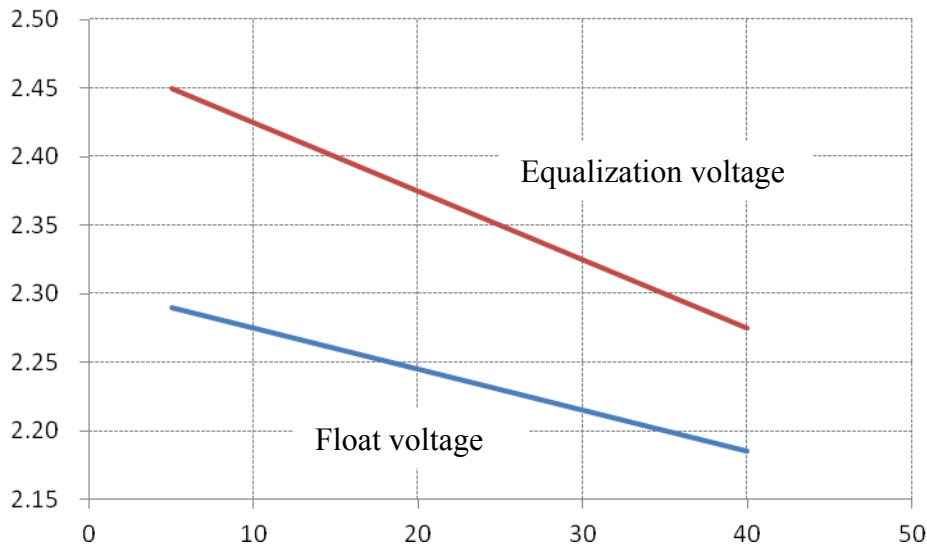

Fig. Float charge and equalization charge voltage curve

3.3 Ambient Temperature Vs. Battery Life

Temperature increase will harm battery and decrease battery life. When temperature exceeds 25°C, the battery life will decrease half per 10°C temperature raise. For example, the designed life of battery at 25°C is 18 years, when battery operates at 35°C for a long period; the actual life may fall to 9 years.

$$L_{25} = L_T \times 2^{(T-25)/10}$$

- Notes: T the actual ambient temperature;
- L_T is designed life at T ambient temperature
- L₂₅ is designed life at 25°C ambient temperature

With the increase of ambient temperature, the corrosion of battery grid and water loss is increase which leads to battery life reduction. It is very important to control ambient temperature.

It's liable to harm battery or even cause heat run away when heat accumulates. If temperature is too high, it must decrease temperature by using air conditioner or providing good ventilation. Please leave over 10mm between batteries and the ground. Meanwhile, adjust the float voltage and equalization voltage according to manual.

4. Choose Battery

Please select batteries' capacity according to Fig. 3-3 Selection Curve of Cell Type.

- 1) First confirm end voltage.
e.g., required end voltage is 1.80V/cell.
- 2) Confirm the continual working time and discharge current.
E.g., the continual working time is 3 hours, and the discharge current is 125A .You should choose the minimum capacity is 70PzV 500(GFMJ-500)
- 3) Confirm the environmental

When the ambient temperature is 25°C, you should choose 70PzV 500. Or you should confirm the temperature coefficient according to the Fig.3-1. If the temperature is below 0°C, there leaves 80% capacity compared with that at 25°C.Then you should divide by 0.8.

4) To ensure the life of the battery, please do not discharge the depth of battery too much. You'd better control the DOD below the 80%, especially in the power shortage areas. There should be some surplus capacity after each discharge to prevent from long-term insufficient charge which gives harm to battery.

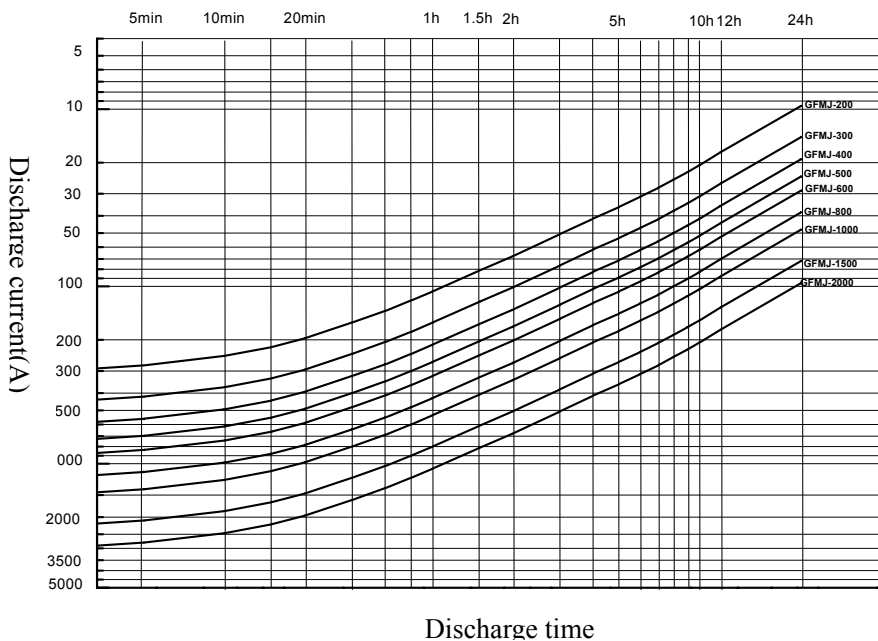

Fig.3-3 Battery selection (end voltage: 1.80VPC)

5. Requirement for Charge

5.1 Equalization Charge

The battery need an equalization charge in the following conditions:

- a. The float voltage of over two batteries are lower than 2.18V.
- b. Floating operation for three months.

The method of equalization charge is suggested as follows:

Charge the battery group on the constant current of 0.1C10A~0.15C10A. When the average voltage up to the equalization voltage, the charging current will decrease automatically. Keep the

constant equalization voltage. The equalization charge should last 24 hours.

5.2 Charge after discharge

Batteries should be charged in time after discharge. The method is recommended as constant current and limit voltage charge. Charge the battery group on the constant current of $0.1C_{10}A \sim 0.2C_{10}A$. When the average voltage is up to a settled voltage, the charging current will decrease automatically. Keep the constant voltage till end. The settled voltage could be float voltage. But when depth of discharge is heavy, such as more than 10%, we recommend to set up equalization voltage so that charge will be more sufficient. We can also decide voltage according to initial current. If the current is larger than $0.05C_{10}A$, we recommend to set up equalization voltage. Normally Charging Time is 24hours. We can judge charge time according to Fig. 3-4. Usually in condition of constant voltage, the value of charge current hasn't varied for continuous three hours, charge can be finished.

We can raise current if the battery group need to charged in a short time, but not higher than $0.25C_{10}A$.

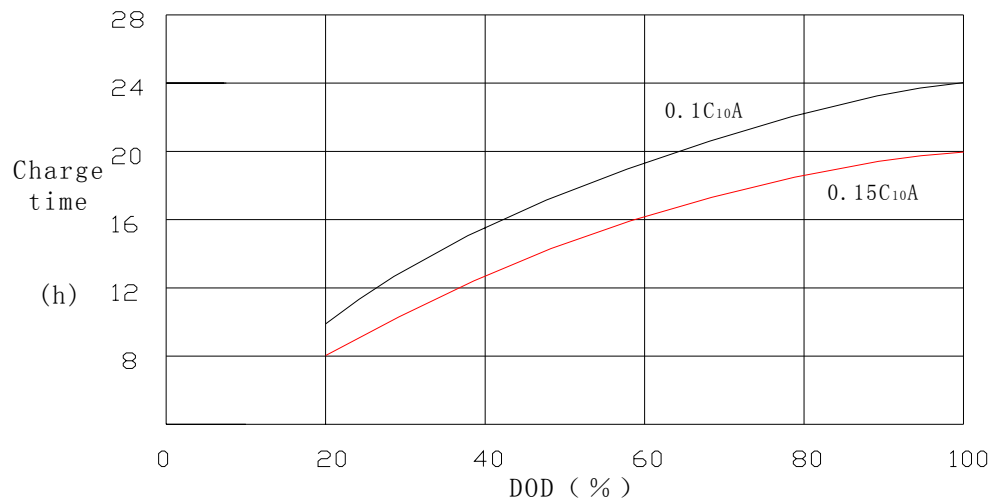

Fig. 3-4, DOD Vs Charge Time

6. Storage

Batteries will experience self-discharge in open circuit. The result is that the voltage of open circuit is decreased, and the capacity also decreased. During storage please note:

a. The self-discharge rate is related with ambient temperature. The self-discharge degree is smaller when the ambient temperature is lower, otherwise is larger. The requirement temperature of Narada polymer batteries' storage environment is from 0°C to 35°C. The storage place must be clean, ventilated and dry.

b. An important parameter in storage is open circuit voltage, which is related with density of the electrolyte. In order to avoid permanent damage to the plate caused by self-discharge, the batteries should be supplementary charged if they have been stored for six months or open circuit voltage below 2.10V/cell. The equalization charge method should be adopted.

c. All batteries, which are ready to store, should be fully charged before storage. It's suggested that record the storage time in the periodic maintenance record and record the time when another necessary supplementary charge should be made.

d. The quality certificates of GEL batteries record the latest charge time of the batteries, next charge time can be calculated according to this charge time.

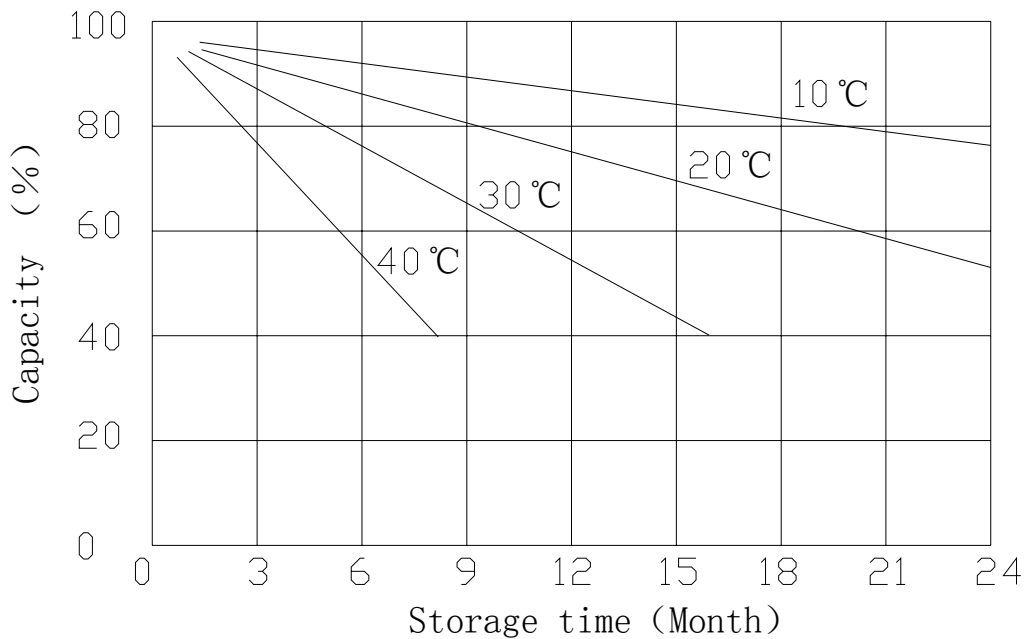

Fig.3-3 Battery capacity Vs. Storage Time

7. Maintenance

In order to assure service life, the batteries should be correctly inspected and maintained. The maintenance methods of GEL batteries are recommended as follows:

7.1 Monthly Maintenance

Implement the under-mentioned inspection every month:

- Keep the battery-room clean.
- Measure and record the ambient temperature of the battery-room.
- Check each battery’s cleanness; check damage and overheating trace of the terminal, container and lid.
- Measure and record the total voltage and floating current of the battery system.

7.2 Quarterly Maintenance

- Repeat monthly inspection.
- Measure and record floating voltage of every on-line battery. If more than two cells’ voltage is less than 2.18V after temperature adjustment, the batteries need to be equalization charged. If the problem is still existing after adopting above-mentioned measures, the batteries need yearly maintenance or even three years’ maintenance. If all methods are ineffective, please contact us.

7.3 Yearly Maintenance

- Repeat quarterly maintenance and inspection.
- Check whether connectors are loose or not every year.
- Make a discharge test to check with exact load every year, discharging 30-40% of rated capacity.

7.4 Three-year Maintenance

- Make a capacity test every year after three years’ operation. If the capacity of the battery decreases to lower than 80% of rated capacity, the battery should be replaced.

7.5 Operation and Maintenance Precautions

- A. Insufficient Charge

If the floating voltage is not set correctly (too low or not amend according to temperature), the battery system will in an insufficient charge state for a long period of time. When the electricity is out, the battery may not be able to work because the acid is saltized and the capacity is decreased.

B. Over Charge

Please do not neglect the performance of rectify to transfer floating charge to equalization charge. If the rectify cannot transfer charge modes because of its wrong performance or no adjustment, the battery system is always in an equalization charge state. Thus may cause serious problems for battery, such as water loss, life decrease, heat out of control, deformation, etc.

C. Too low or too high temperature

We have mentioned that too low temperature will affect the capacity of battery. While too high temperature will also cause problems, such as water loss, life decrease, heat out of control, deformation, etc.

D. Too low end voltage

The end voltage is also an important parameter for battery. The battery shall stop discharging when reach a certain voltage (The normal end voltage is 1.8Vwith 10-hour rate). If the end voltage is too low, it will be difficult to recharge the battery and decrease the charge efficiency, thus reduce the life of battery. Table3-5 shows the end voltage with different hour rates.

E. Do charge the battery immediately after discharge.

If the battery is put aside without charge for a long time after discharge, it will affect the capacity and life of the battery. Because some large size $PbSO_4$ will create in the negative which are difficult to transfer to active Pb.

Chapter 4 After Sales Service

Quality policy of Narada: Strictly selected material, accurate manufacturing, High technology, sincere service.

- Assist the design and offer type selection service.
- We will offer a service guarantee within the designed life if you use the battery correctly.
- Answer the complaint within 24 hours and deal with them in time.
- Debug the battery according to users requirements on the spot.
- Hold regular training classes about the operation and maintenance of the VRLA.
- Establish an excellent files on each of customers and pay regular visit to them.

If you have any problem, please contact us:

Service Department

P.R. China:

Tel: (+86-571)28827013/ 28827016

Fax: (+86-571)28828290

E-mail: intl@narada.biz

Website: www.naradabattery.com

VRLA Battery Regular Maintenance Record

Battery type			System voltage			Battery capacity					
User			Site place			Temperature					
Float voltage			Float current			Load					
No.	Cell series No.	Charge voltage	Discharging/(Charging) voltage vs. time								Note
1											
2											
3											
4											
5											
6											
7											
8											
9											
10											
11											
12											
13											
14											
15											
16											
17											
18											
19											
20											
21											
22											
23											
24											
Total voltage(V)											
Display voltage(V)											
Current(A)											
Result:											
Tester			Date								